

**ROBOT PALETIZADO RP-400**

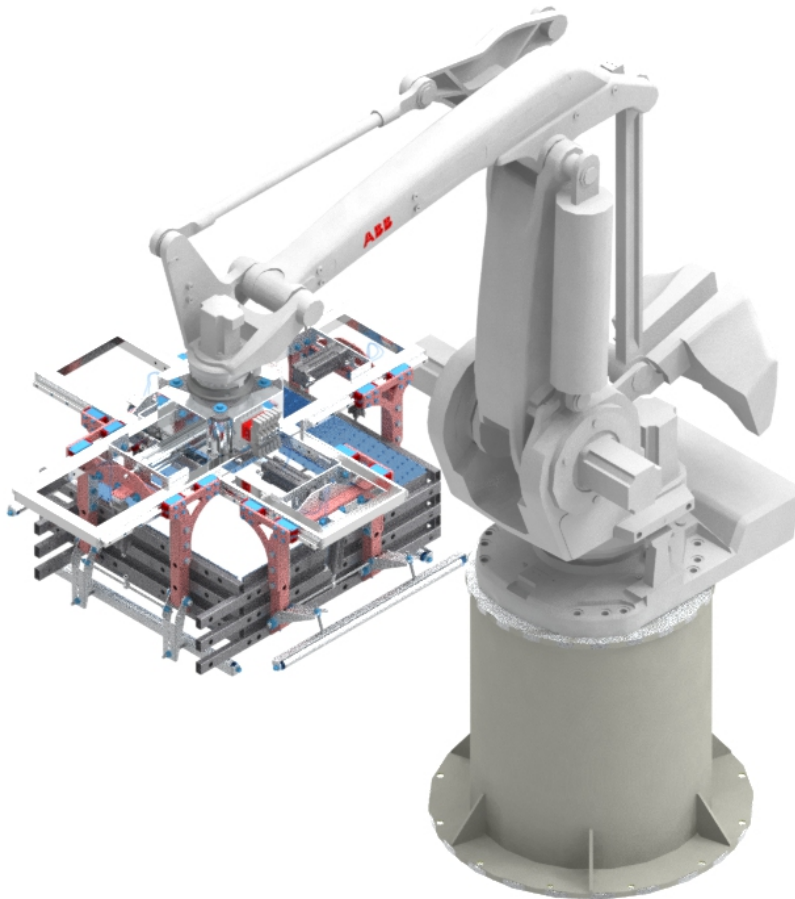

**DESCRIPCIÓN**

**DIMENSIONES**

Longitud (mm)	
Ancho (mm)	
Alto (mm)	
Peso (mm)	
Area (m <sup>2</sup> )	

**CONSUMO**

Electrico (kW)	
Aire (l/h)	
Presion (Bar)	
Gas-Oil (l/h)	
Gas (m <sup>3</sup> /h)	